

SUNLINE

DUAL MONITOR ARM

SKU: 580

MATERIALS

- **Body:** Steel
- **Arms:** Aluminum
- **Mount Parts:** Plastic
- **Finish:** Powder coating

FEATURES

- **Optimized Desk Space:** Enhances efficiency and ergonomics
- **Monitor Compatibility:** Supports 13"-27" monitors up to 17.6 lbs
- **Full Motion Flexibility:** 90° swivel, tilt, ball-joint positioning, and vertical adjustments
- **360° VESA Plate:** Rotates fully for ideal viewing angles
- **Height Adjustable:** Ergonomic positioning made easy
- **Cable Management:** Keeps workspace tidy
- **Dual Mounting:** Desk clamp and grommet options included

SPECIFICATION

- **A Width:** 29"
- **B Depth:** 5"
- **C Height*:** 22"

*18" above the desk and 5" below the desk

IN-STOCK / FINISHES



Black

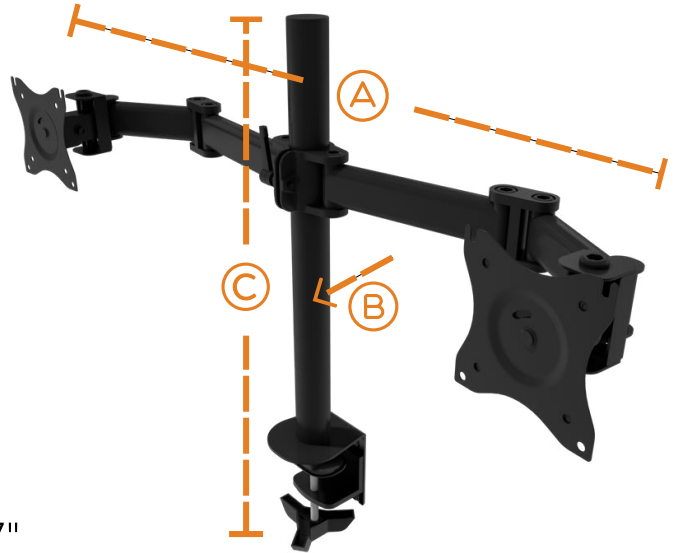

SUNLINE

DUAL MONITOR ARM

SKU: 580

RANK	FIT SCREEN SIZE	SCREEN QUANTITY	WEIGHT CAPACITY	INSTALLATION	SUGGESTED DESKTOP THICKNESS
Standard	13" - 27"	2	17.6 lbs	Clamp, Grommet	Clamp: 0.39"~3.5" Grommet: 0.39"~3"
TILT RANGE	SWIVEL RANGE	SCREEN ROTATION	ARM FULL EXTENSION	POLE HEIGHT	VERSA COMPATIBLE
+45°~-45°	+90°~-90°	+180°~-180°	14.3"	17.7"	75x75, 100x100

